



## **INSTALLATION & TECHNICAL INFORMATION**

PLEASE READ PRIOR TO INSTALLATION



### **Klaxon Intrinsically Safe Beacon Range**

S00609KL, Issue 6, 19/10/2021

#### **VISUAL SIGNALLING DEVICES**

APPROVALS AND CONFORMITIES



[www.klaxonsignals.com](http://www.klaxonsignals.com)

[sales@klaxonsignals.com](mailto:sales@klaxonsignals.com)

## 1.0 Introduction

The Klaxon Intrinsically Safe Beacon Range of products (TCC-000X) are ATEX and IECEx certified. This range is approved to be installed in Groups I (Mining) and Group II (above ground), Zones 0, 1 or 2 with gas groups IIA, IIB, IIC and Zones 20, 21 and 22 for dust groups IIIC and carries a temperature classification of T5. The Beacon Range has a DIP switch that gives the option to change the 1Hz flash signal to a static (constantly on) signal. When powered via a suitable Galvanic Isolator or Zener Barrier the Sounder will draw a constant 33mA. The Beacon Range has diode reverse polarity protection and is also End of Line resistor compatible.

## 2.0 Intrinsically Safe Labelling

All products will have an individual serial number printed onto the head base plate. An example of the Beacon label is shown below.

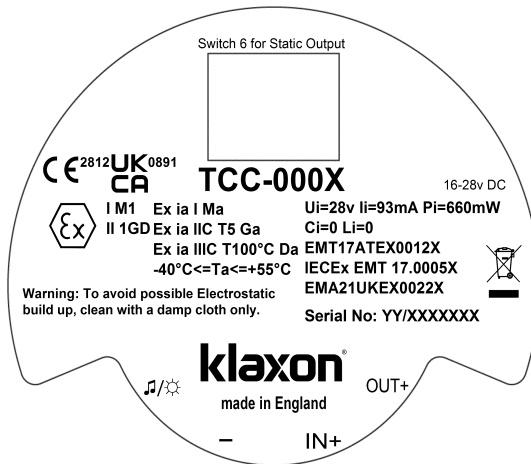

These products have been tested by notified body **Element Materials Technology**, who are UKAS accredited to BS EN ISO/IEC 17025:2005 and ISO/IEC 17065:2012. It is also a Notified Body for the ATEX Directive, UKEX (UKCA), an IECEx Certification Body and an IECEx Testing Laboratory.

The suffix X at the end of the certificate numbers indicate that there are special clauses added for safe use of these units.

## 3.0 Types of Approval and Standards Applied

The Klaxon IS product range all have been approved to the following standards:  
IEC 60079-0:2011 / EN 60079-0:2018  
IEC 60079-11:2011 / EN 60079-11:2012

## **4.0 Zones, Gas Groups and Temperature Classifications**

The Klaxon Intrinsically Safe Beacon Range is certified to the following:

Ex ia IIC T5 Ga, Ex ia IIIC T100C Da, Ex ia I Ma.

This means that the units can be installed in locations with the following conditions when connected to an approved system:

### Zones

Zone 0	Explosive gas air mixture continuously present.
Zone 1	Explosive gas air mixture likely to occur in normal operation.
Zone 2	Explosive gas air mixture not likely to occur, and if it does, it will only exist for a short time.
Zone 20	Explosive dust air mixture is continuously present.
Zone 21	Explosive dust air mixture likely to occur in normal operation.
Zone 22	Explosive dust air mixture not likely to occur, and if it does, it will only exist for a short time.

### **Gas Groupings**

IIA Propane Group, IIB Ethylene Group and IIC Hydrogen and Acetylene  
M1 Methane, Carbon Dust

### **Equipment Category**

1GD & M1 Temperature Range:  $-40^{\circ}\text{C} < T_a < 55^{\circ}\text{C}$

### **Dust**

IIIA Fibres and Flying, IIIB Flour and Grain, IIIC Coal Dust and Metal Dust.

The maximum surface temperature of the product during operation will not exceed  $100^{\circ}\text{C}$ .

A Declaration of Conformity and also the Beacon Range ATEX and IECEX Certificates are available on request or alternately visit

**[www.klaxonsignals.com](http://www.klaxonsignals.com)**

## 5.0 Installation

The TimeSaver base enables quick and easy installation of these unit with no extra cabling to be made to the head of the unit. Connections are made to the base during the initial wiring phase which results in faster and more reliable installation. The Beacon head 'twists and clicks' into the base on commissioning, thus avoiding any wiring or connection problems associated with traditional installations.

If required, the mechanism for locking the Beacon to the base can be activated by removing the thin section of plastic shown in Fig. 1 with side cutters or a similar tool. To open a locked head remove the small rubber bung from the hole on the side of the beacon and insert a tool into the hole and depress the clip whilst twisting the head. The O-ring and bung must be re-fitted to maintain weatherproofing.

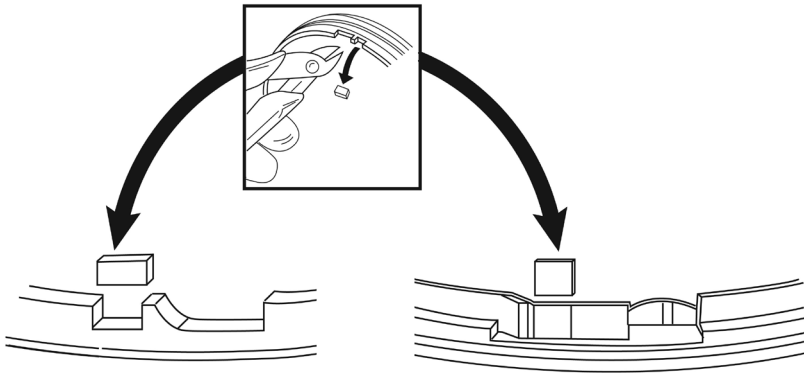

## General Requirement

The product must be installed in accordance with the latest EN60079-0 specification or the equivalent IEC specification, with consideration for any local installation requirements, and should only be carried out by appropriately competent and qualified personnel.

- The location of the unit should be chosen with due regard to the area over which the signalling device must be visible and/or audible.
- Environmental exposure conditions during installation should be dry. Moist or wet conditions should be avoided.
- Avoid mounting the beacon where it will be subject to excessive vibration.

## To mount the unit

- Remove the head from the base by rotating anticlockwise until it comes free.
- Remove the appropriate fixing hole and conduit knockouts from the back box.
- The back box (see page 5) provides IP66 protection, for this to be maintained suitable seals must be used around the mounting screws. Suitably rated (minimum IP66) M20 cable glands must also be used for cable entry/exit.
- Insert cable glands and attach to surface.
- Select required wiring option for required operation (see wiring section 6.0).
- Select static or flashing output using DIP switch, see setting table below:

Light Output	Switch 6 Position
Flashing	OFF
Static	ON

- Relocate head onto mounted base unit & rotate clockwise until locked in place.

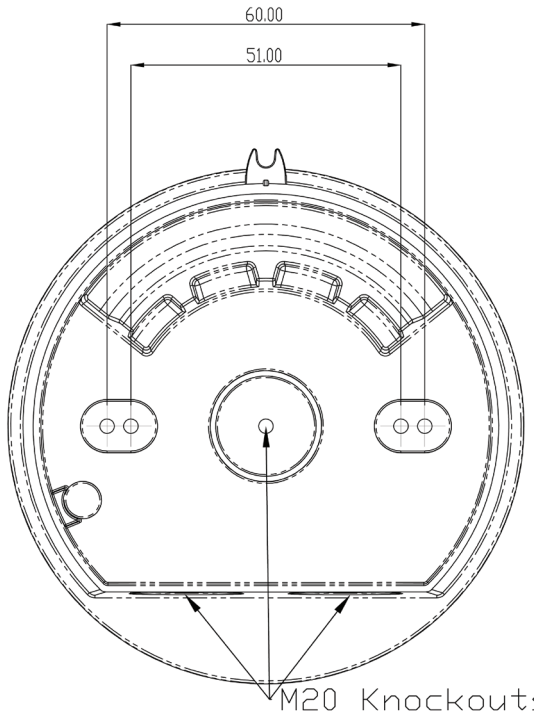

## 6.0 Wiring



Line	Terminal Marking
Common Positive Supply IN	(3) IN+
Sounder Negative Supply	(2) -
Beacon Negative Supply	(1) 

Table above indicates markings inside the base of the unit for wiring connections.

**Each unit must be powered via an approved Zener Barrier or Galvanic Isolator whose entity parameters do not exceed:**

**Uo:28v, Io: 93mA, Po:660mW, Ci:0, Li:0**

Operation of the Beacon unit (TCC-000X) can be taken from the table below:

Line	Terminal Marking	Beacon (TCC-000X)
Common Positive Supply IN (Uo)	(3) IN+	+
Sounder Negative Supply	(2) -	
Beacon Negative Supply	(1) 	-

End of line monitoring is applicable to the Intrinsically Safe Beacon Product Range. For this to function correctly the resistor must be connected between the IN+ terminal and the Beacon Negative Supply.

## **7.0 Maintenance**

Little or no maintenance is required during the normal working life of the product. The Klaxon Intrinsically Safe enclosures are resistant to most acids, alkalis and chemicals and have been designed to withstand severe weather conditions. However it is suggested that continuous supervision and periodic inspections may be required in relation to the requirements of the installation as per IEC 60079-17. To avoid the possibility of a potential electrostatic charge build up, it is recommended that the exterior of the product is periodically wiped down with a clean damp cloth. At this point a visual inspection is recommended to ensure that the product is in good working order and no damage has been sustained during its normal operation. In the case of dust fibres or flyings, the level of supervision may influence the inspection and maintenance requirements.

## **8.0 Conditions for Use**

The Klaxon Intrinsically Safe Signalling Range uses an enclosure rated at IP66. To ensure that this rating is maintained once installed, a suitable cable gland must be used which matches this level of protection. The base of the units contains 3x M20 knockouts for wiring in purposes, and only those required should be used. Any that are removed must have at least an IP66 rated gland fitted with cable passing through it or suitable plug.

The enclosure is non-conducting and may generate an ignition-capable level of electrostatic charge under certain extreme conditions. It is the responsibility of the user to ensure that the equipment is installed in a location where it will not be subjected to external conditions that might cause a build-up of electrostatic charge on the surface of the unit, additionally; cleaning of the equipment should be done only with a damp cloth.

The units must be powered via a suitable Zener Barrier or Galvanic Isolator whose characteristics do not exceed:

**Uo:28v, Io: 93mA, Po:660mW**

The value for Uo must be between **16v and 28v**, and Io should not be below 50mA.

The Intrinsically safe Beacon range of products is only to be powered via a correctly rated Zener Barrier or Galvanic Isolator. To power these units up without the correctly rated barrier could damage these products and so void any protection ratings.

**Specific Conditions of Use:**

1. Clean equipment regularly to prevent dust build-up with a damp or anti-static cloth only.
2. Equipment only suitable for fixed installation.
3. It must be ensured that the equipment is installed in accordance with IEC 60079-4 and IEC 60079-25 and that capacitance and inductance limits are not exceeded by distributed capacitance (Cc) or distributed inductance (Lc) due to cable length.

<b>Table of Entity Parameters</b>	
<b>Parameter</b>	<b>Barrier Supply</b>
Ui	28V
Ii	93 mA
Pi	660 mW
Li	0
Ci	0